

# **HIGH SPEED HIGH RISE**

**ELEVATOR**

**FUJITEC**

[www.fujitec.com](http://www.fujitec.com)





WORLDWIDE ACHIEVEMENT



- |   |   |   |   |   |
|---|---|---|---|---|
| 1 | 2 | 3 | 6 | 7 |
|   | 4 | 5 |   |   |
|   |   |   |   |   |
- ① New York times Tower (New York)
  - ② The Cullinan (Hong Kong)
  - ③ Pullman Shanghai Skyway (Shanghai)
  - ④ Shanghai Bank HQ (Shanghai)
  - ⑤ Manhattan Place (Hong Kong)
  - ⑥ HSBC HQ (London)
  - ⑦ 900 North Michigan Avenue (Chicago)

① FUJITEC TECHNOLOGY

② COMFORT AND SAFETY

③ ECO CONSCIOUSNESS

④ TRAFFIC MANAGEMENT

# FUJITEC

INNOVATIVE SOLUTION FOR HIGH SPEED/HIGH RISE EXPERIENCE

Speed (m/min.)	Capacity (kg)				
	1000	1150	1350	1600	2000
150	■	■	■	■	■
180	■	■	■	■	■
210	■	■	■	■	■
240	■	■	■	■	■
300	■	■	■	■	■
360	■	■	■	■	■
420	■	■	■	■	■
480	■	■	■	■	■
600	■	■	■	■	■

\* Consult Fujitec for specifications in detail.



# FUJITEC TECHNOLOGY

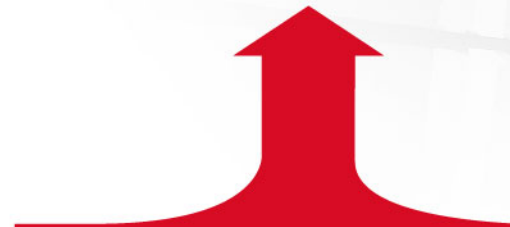

## CONTROL SYSTEM

The latest printed circuit board which is the proprietary product of Fujitec has improved not only reliability by featuring the RISC chip, but also performance by enabling higher processing speed than in our conventional products.

A smoother riding experience has been ensured by constructing the position/speed control with a two-degrees-of-freedom (2 DOF) control system by closed-loop system where the encoder signals are fed back, and by simultaneously controlling response and suppression of external disturbances.

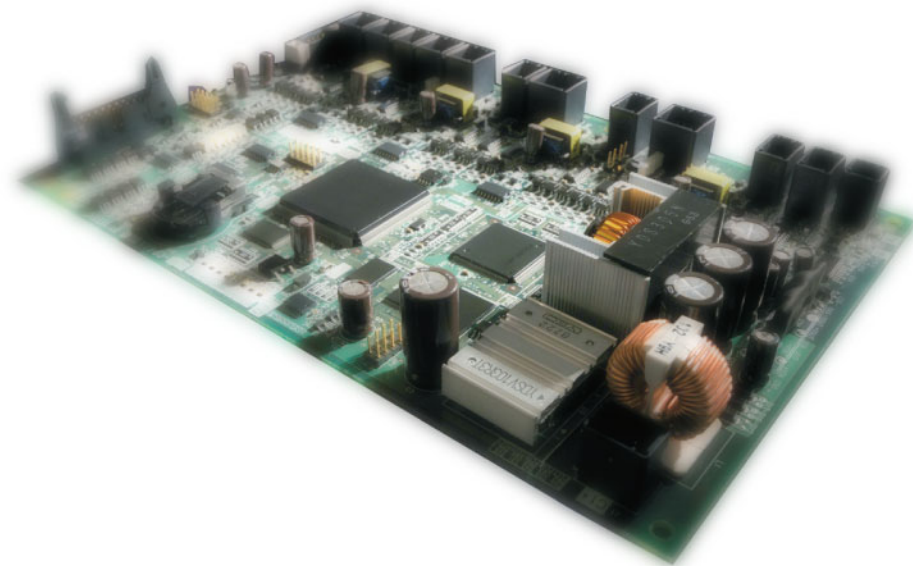

## DRIVING SYSTEM

The drive system of Fujitec high-speed elevators features a PM gearless motor. Through our R&D work which utilizes state-of-the-art CAE technologies and our own technical expertise accumulated over many years as a specialized elevator manufacturer, we have achieved in developing a compact traction machine where the machine weight is reduced by up to 30% compared to the machine weight of our conventional models.

Furthermore, the performance of the traction machine motor has also been improved by in-depth analysis and optimization of the magnetic circuit.

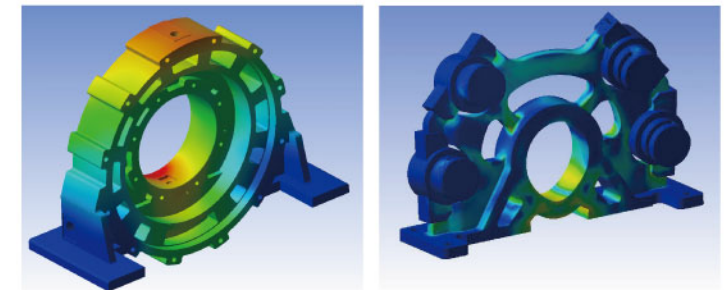
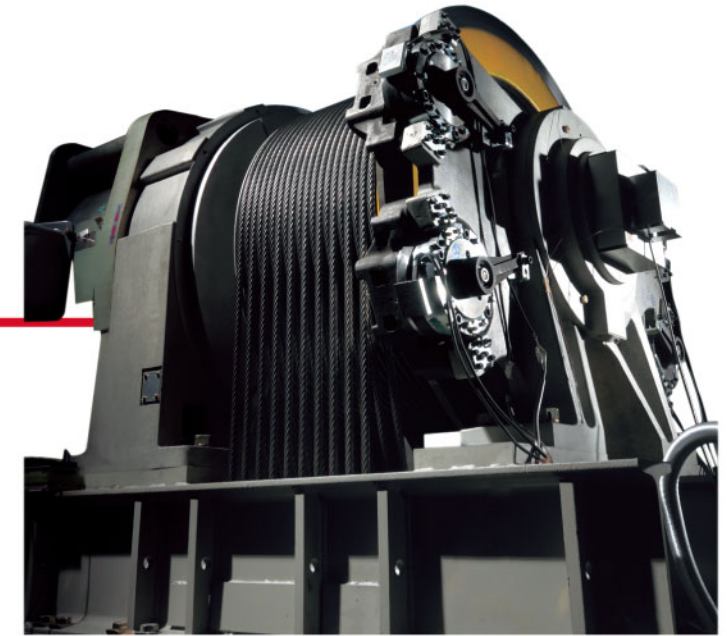

Structural Analysis utilized CAE Technology

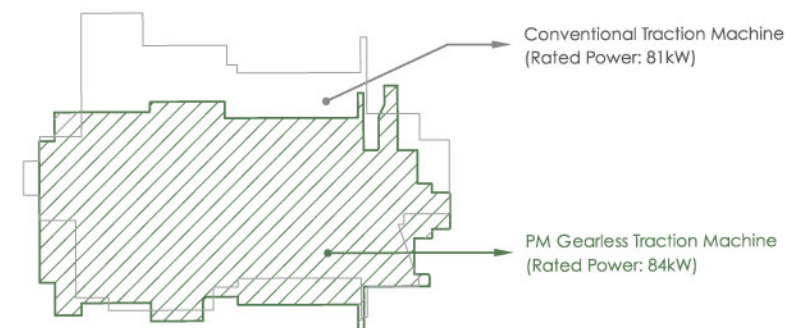

Appearance comparison with conventional Traction Machine

\*This machine is applied to the elevator with capacity 2000kg and speed 480m/min



# COMFORT AND SAFETY

## COMFORTABLE RIDE

For an elevator car that goes up and down at ultra-high speeds in a narrow hoistway, measures for dealing with fluidized air as a design factor are absolutely critical. Therefore, we apply the knowledge gained from joint research with Dome Co., Ltd., a world-renowned racing car constructor, to the equipment development review in order to minimize the effects of airflow. As a result, the noise and vibrations are vastly improved, thereby achieving superb riding comfort during high-speed travel.

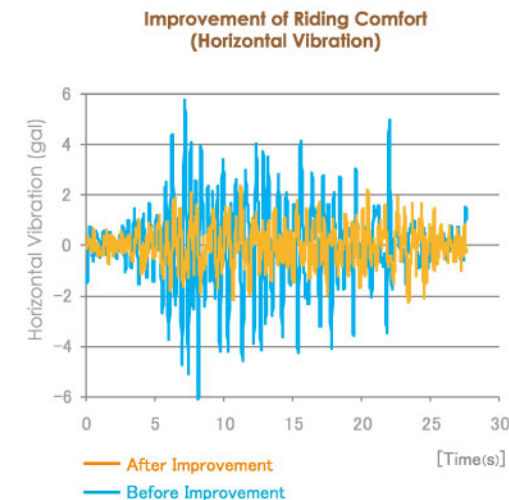
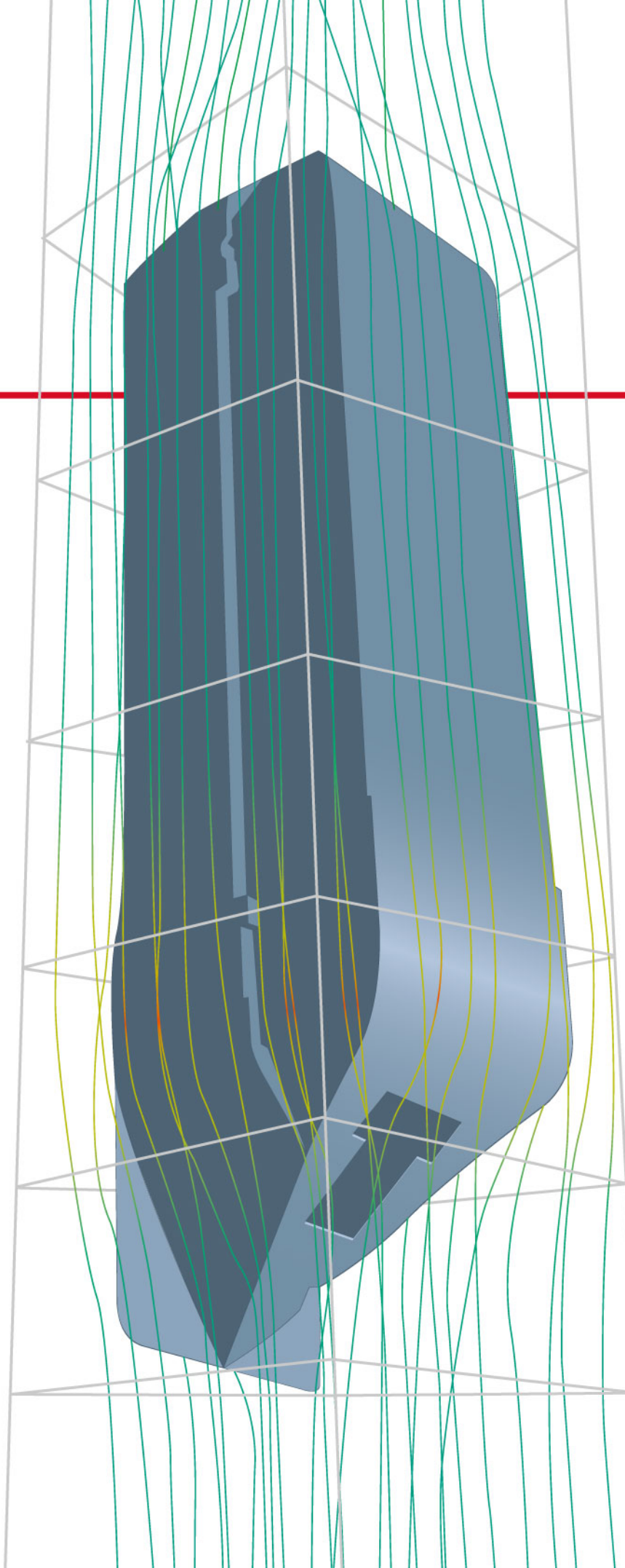
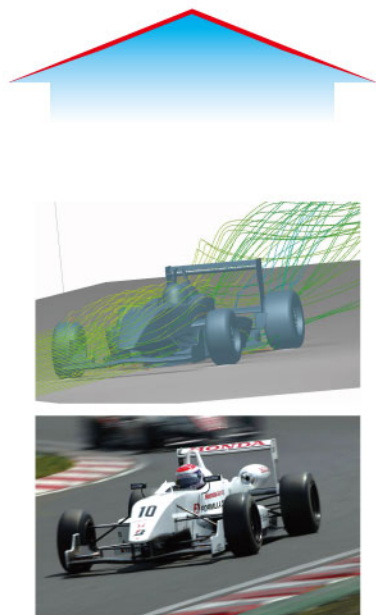

As the only means of speedy transportation in buildings, elevators require a high degree of quietness and riding comfort. Consequently, Fujitec has been in a quest to fulfill these requirements during the development and design phases of elevator equipment. Regarding hardware aspects, the high operational efficiency and comfortable ride are ensured by improved vibration through our R&D work on components where CAE technologies are fully utilized. For software aspects, the same is achieved by direct leveling without creeping at low speeds, vector control by a high-performance inverter and PWM motor control by a high-response current control.

## SAFETY OPERATION

Countermeasure against earthquake

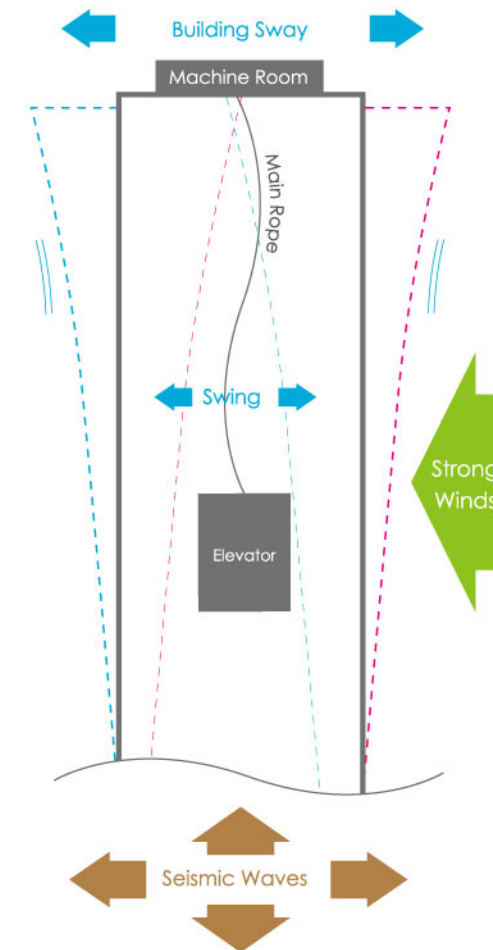

For high-rise buildings, emergency elevator operation modes that respond to building sway caused by earthquakes or strong winds are required to ensure the safety of elevator users. In addition to the seismic operation mode that detects the primary and the secondary waves, emergency operation modes customized to individual buildings, such as an operation mode that initiates after building sway is detected with a sensor that can detect long-period ground motions and evacuates passengers to the nearest floor or stops the car at an intermediate floor where the building is not affected by resonance until the quake subsides will be executed.

In addition to detecting earthquakes, the emergency operation mode of long period seismic ground motion also predicts and analyzes increases in rope sway caused by strong winds and executes an emergency operation mode that is suitable for the situation.



# ECO CONSCIOUSNESS

## ELECTRICITY RECYCLING SYSTEM

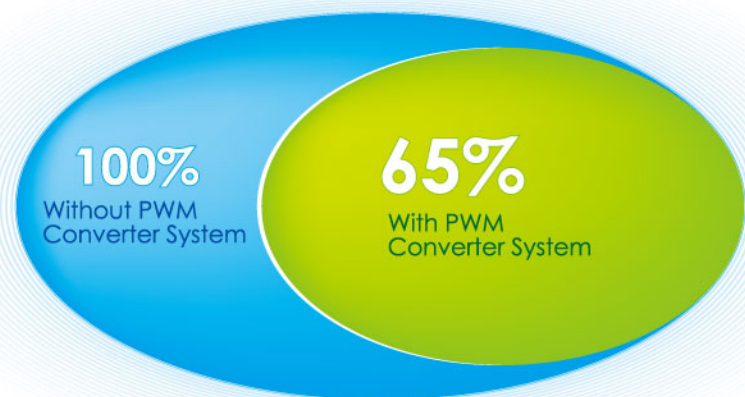

ENERGY SAVING EFFECT DIAGRAM

A PWM converter is featured in high-speed models, which returns 'regenerated' power that is generated by the motor during the full-load down or no-load up operations to the power supply unit. The regenerated power contributes to the overall reduction in power consumption since it can be used by other electric power equipment installed in the building. The power consumption can be reduced by about 35%, compared to an elevator system that is not provided with a PWM converter.

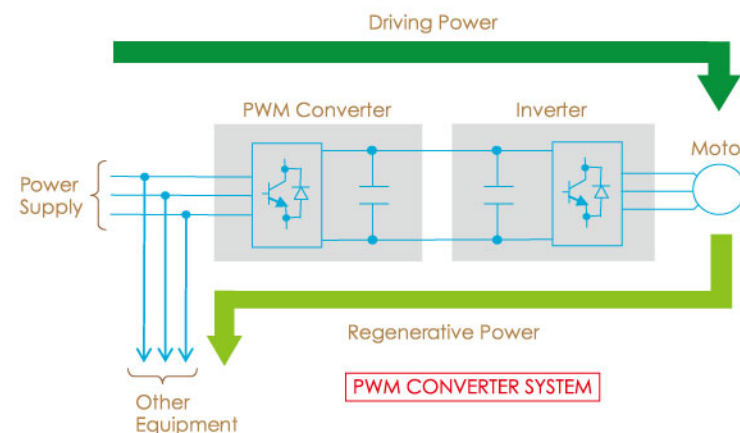

## PM GEARLESS TRACTION MACHINE

Fujitec high speed elevator adopted Permanent Magnet Gearless Synchronous Traction Machine that enormously contributes to ecological environment and economical consumption in a building.

### Energy Saving

PM Gearless Traction Machines are extremely efficient reducing energy consumption to an absolute minimum.

### Less Pollution

As gearless permanent-magnet motor does not require oil or other polluting agents, this is helpful for a cleaner environment.

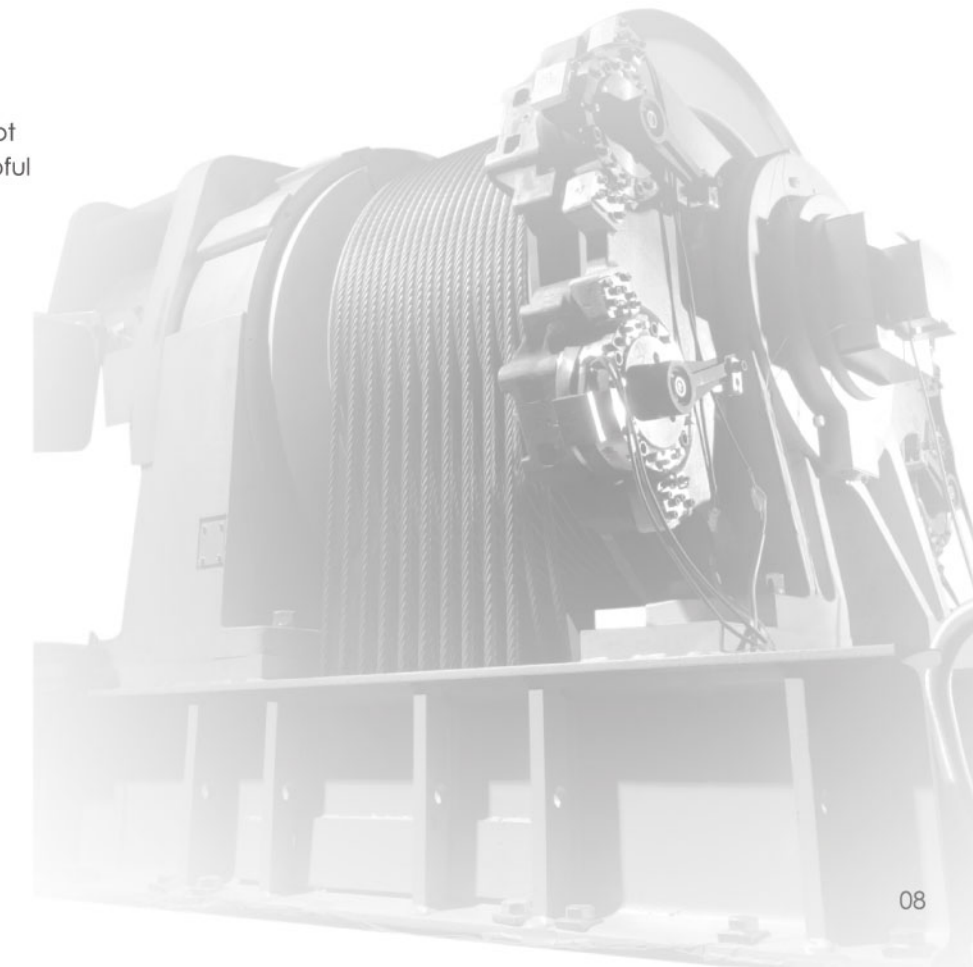



# TRAFFIC MANAGEMENT

## NEW-GENERATION ELEVATOR GROUP SUPERVISORY CONTROL SYSTEM FLEX-NX SERIES

### Virtual Passenger Optimization Method

Fujitec has newly employed the Virtual Passenger Optimization Method, which virtually calculates the long-range waiting time of each passenger, based on extrapolated passenger arrival rates by travel direction at each floor from past learned data in order to execute the group supervisory control.

The system probabilistically extrapolates the number of passengers who arrive later at a stop where a hall call had already been registered or passengers who arrive at a stop where no hall call had been registered and then the system comprehensively calculates the passenger waiting time.

With such a design, it is possible to accurately reflect and predict the traffic situation of the whole building for the elevator traffic control, thereby enabling a reduction in the average daily waiting time for all passengers by up to 10%.

Comparison of Average Daily Waiting Time

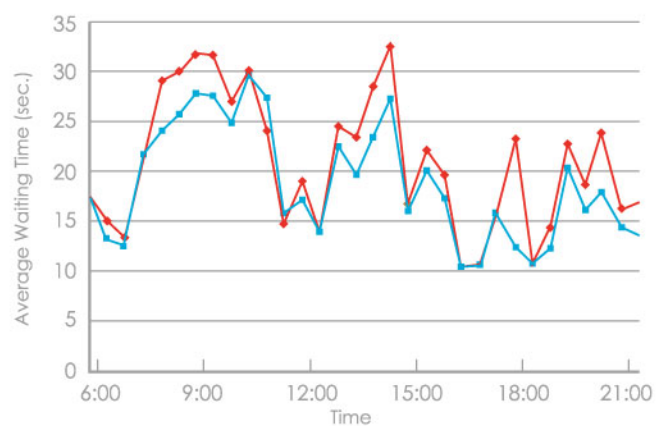

◆ Conventional Group Supervisory Control System  
◆ Virtual Passenger Optimization Method

\* The graph shows the results of a simulation to reproduce the daily traffic in an actual high-rise condominium having three elevator units and 33 stops.

## DESTINATION RESERVATION GUIDANCE SYSTEM (Optional)

For a short duration many users are concentrated on the lobby floor of office buildings during the up-peak period. Conventionally, elevator users register a hall call in the desired direction and board an arriving elevator irrespective of the destination floor. Therefore, the elevator may stop at many floors when transporting passengers, resulting in a longer journey time.

With the Destination Reservation Guidance System (optional specification), a passenger uses the Destination Floor Registration Panel installed near (or within) the elevator hall to register a destination floor. The system uses this data to limit the number of destination floors assigned to each elevator in order to improve transport efficiency; thereby not only easing congestion, but also enabling a reduction in the journey time by up to 30%.

Comparison of Average Journey Time During Up-peak Period

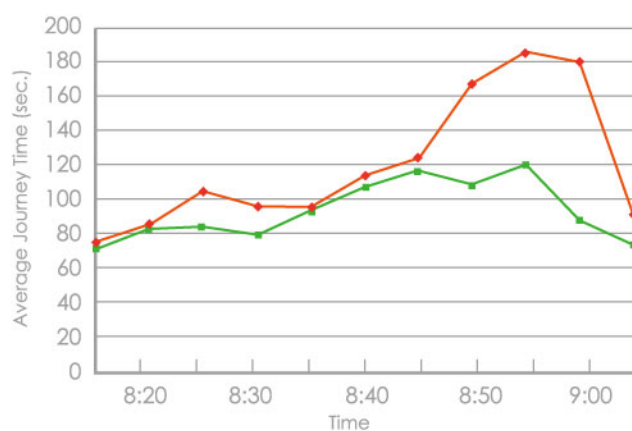

◆ Conventional Group Supervisory Control System  
◆ Destination Reservation Guidance System

\* The graph shows the results of a simulation to reproduce the traffic during the up-peak period in an office building having six elevators and 20 stops.

- Eliminating In-Car Operation
- Easing the Up-Peak Congestion in Office Buildings
- Reducing the Journey Time

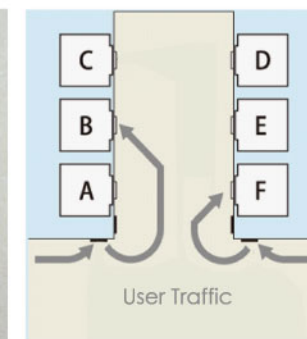
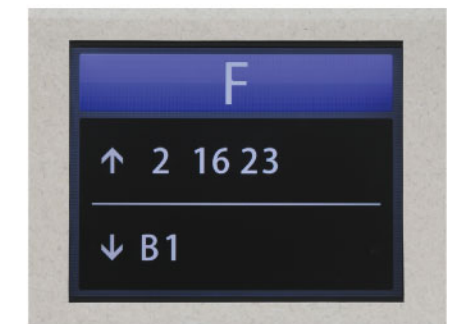

Destination Floor Registration Panel

Destination Floor Indicator